

Ceilings

Ceilencio Custom

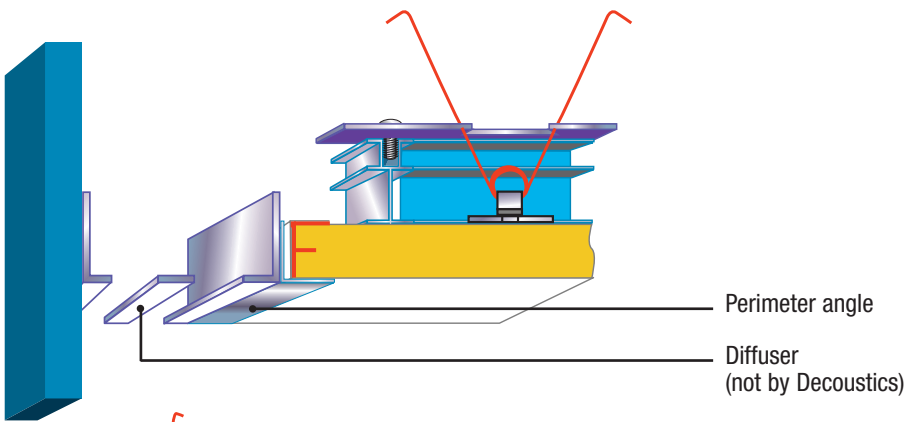

Perimeter Conditions

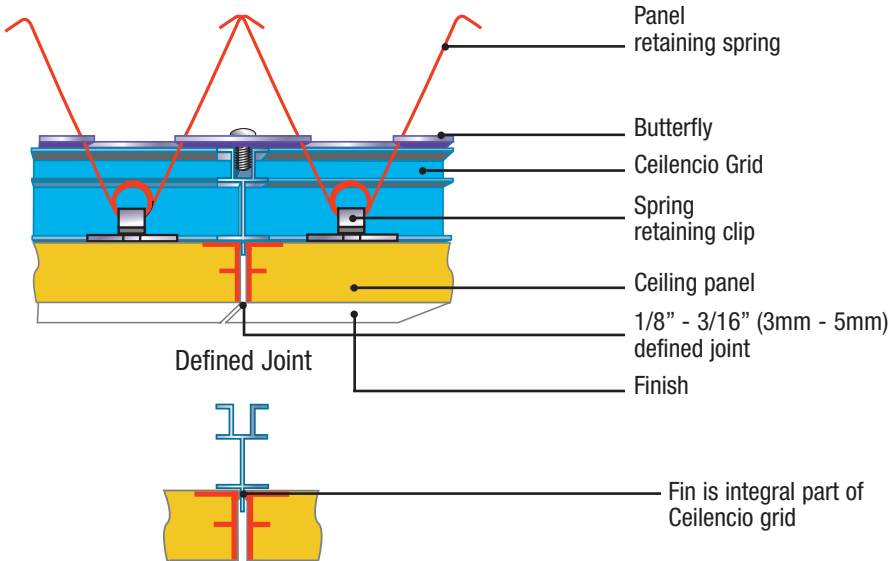
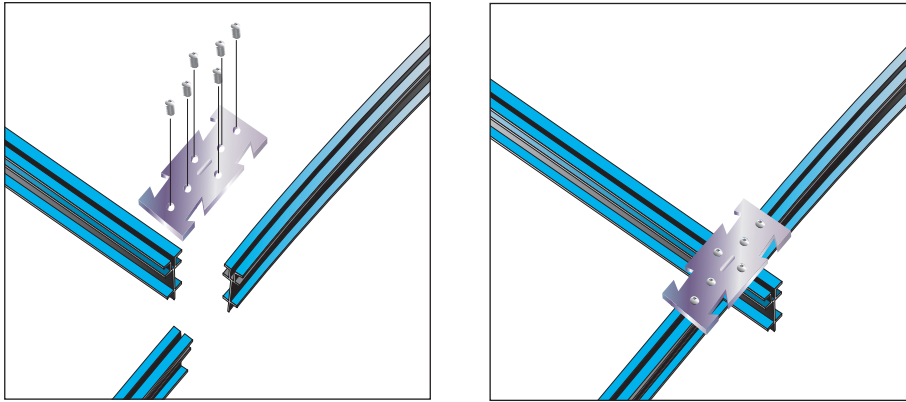
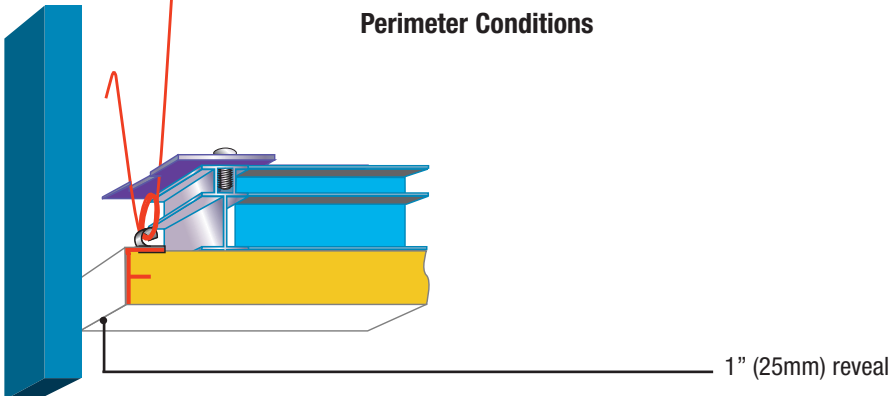

Description

Decoustics Ceilencio Custom is an integrated acoustical panel ceiling system consisting of a proprietary concealed extruded aluminum grid and panels. A clear vapor retarder is adhered to the back (plenum) side of the panel. The ceiling is 100% accessible via a unique torsion spring mechanism which permits individual panels to be "hinged" down (or completely removed if necessary) for access to mechanical and electrical services. The grid is suspended using hanger wires, rods and similar suspension components.

Panels

All Decoustics panels are custom fabricated and offered in a variety of types, sizes, geometric shapes, vaults, thicknesses and finishes.

Limitations

A minimum space of 5" (125 mm) is required behind the panel for torsion spring clearance. Note: A clearance as little as 2" (50 mm) can be accommodated in specific areas provided careful planning is employed and grid location is coordinated.

Design Considerations

A variety of ceiling perimeter options are available. These include:

- Standard wall mold, flex mold or shadow mold (allows for field cutting of panels).
- A 1" (25 mm) wide or greater reveal to create a floating ceiling look. Reveal can be closed off at back of panel if desired.
- Exposed T-bar or similar at same plane ceilings.
- Continuous slot diffuser or air return.

All lights, diffusers, speakers, smoke detectors, sprinklers, and similar items that penetrate or are located in the ceiling should be located away from panel edges and grid lines and must be independently supported. The panel is not structurally capable of supporting the weight of any of these items.

When using speakers in ceiling or wall panels, it is recommended the speaker grille be visibly mounted at the face of the panel. Speaker function creates air movement and any fabric covering the speaker will experience premature soiling.

...cont'd

Ceilings

Ceilencio Custom

When panel dimensions exceed 48" additional / intermittent springs, spring retainers, butterflies, grid members will be required. Contact Decoustics for project specific details.

Maintenance

Refer to appropriate Decoustics "Cleaning & Maintenance Instructions" for any specific finish.

Related Data

Decoustics 3-Part Guide Specifications.

Seismic Data

Suspended ceiling assemblies incorporating Decoustics "Ceilencio Custom" grid and fabric, vinyl or coated finished panels, meet the requirements of seismic design category D, set forth by the prevailing codes of practice.

Mounting Methods

Install custom suspension grid following manufacturer's printed instructions and shop drawings. Installer to supply all suspension components including ceiling anchors, hanger wire or rods, perimeter moldings and similar hardware. Secure "butterfly" plates over grid intersections ready to receive panels. Insert torsion springs into retainer and crimp closed tight, snap assembly on panel backs. Install retainers and springs onto backs of panels. Lift panels into position and engage torsion springs into "butterfly" plates. If necessary, adjust to compensate for panel manufacturing tolerances. Follow manufacturer's printed instructions for field cutting of panels.

Note: The information provided in this Data Sheet is accurate to the best of our knowledge at the time of printing. However, we reserve the right to make changes when necessary without further notification. Suggested applications may need to be modified to conform with local building codes and conditions. We cannot accept responsibility for products that are not used, or installed, to our specifications. Please refer to our website for most current data.

Note: Only handle panels wearing clean, lightweight, white gloves during installation. Follow manufacturer's printed instructions for installation as well as field cutting of panels.

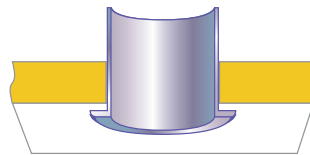

Sprinkler Condition

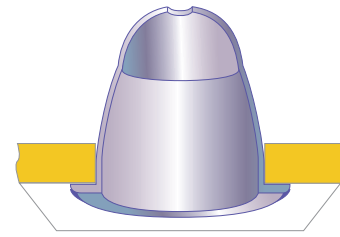

Downlight Condition

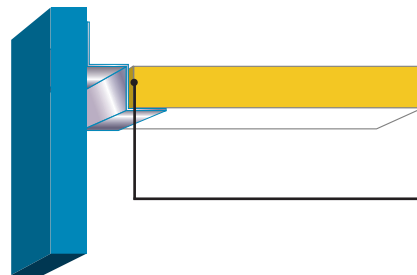

Optional Shadow Molding

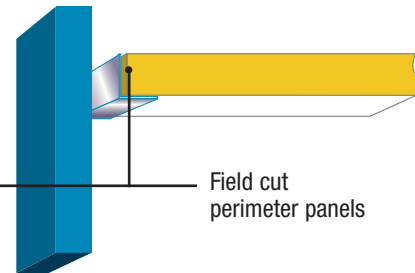

Optional Wall Molding

Field cut perimeter panels

Standards, Tests and Approvals

Surface Burning Characteristics (ASTM E-84):

All panel components have a Flame Spread rating of less than 25.

Note: Building code requirements may necessitate composite panel testing based on specified finish.

A panel comprised of "Class A" (Flame Spread of 25 or less) components does not necessarily produce a composite panel meeting the "Class A" requirement. Decoustics has a considerable number of composite panel tests on file.

Acoustical Data (ASTM C423: Panels were tested using Type E400 Mounting as per ASTM E795).

FINISH	PANEL THICKNESS	FREQUENCY (Hz)						NRC	SAA
		125	250	500	1000	2000	4000		
*Fabric	1" (25 mm)	0.46	0.52	0.94	1.01	1.10	1.13	0.90	0.87
Claro or Metallo	1-1/16" (27 mm)	0.39	0.63	0.83	1.05	1.05	1.00	0.90	0.87
Quadrillo									
QPP-19	Panel 1-1/8" (28 mm) Core 3/4" (19 mm)	0.78	0.77	0.61	0.86	1.04	0.70	0.80	0.82
QPP-25	Panel 1-3/8" (35 mm) Core 1" (25 mm)	0.74	0.79	0.72	1.00	1.02	0.78	0.90	0.88
QPP-50	Panel 2-3/8" (60 mm) Core 2" (50 mm)	0.80	0.87	1.00	1.07	1.06	1.00	1.00	0.98

*Acoustic testing was performed on a panel finished with an acoustically transparent fabric.

The Ceiling Attenuation Class (CAC) as determined by ASTM E1414 for Decoustics panels mounted using the Ceilencio Custom Ceiling system is as follows:

PANEL TYPE/ DDESIGNATION	PANEL THICKNESS	FINISH	CAC
ME/VAP	1" (25 mm)	Fabric	33
MEV/ATT & MEV/MTO	1-1/16" (27 mm)	Claro or Metallo II	32
ME/ATT/STC(S)	1-1/16" (27 mm)	Claro	44
ME/AP/STC(M)	1-1/2" (38 mm)	Fabric	50
ME/ATT/STC(M)	1-9/16" (40 mm)	Claro	50
ME/ATT/STC (C)	1-9/16" (40 mm)	Claro	53

All testing was performed by an NVLAP accredited independent laboratory.

Ceilings

Ceilencio Custom

FINISH	EDGE OPTIONS	SIZES	CONSTRUCTION	THICKNESS	NRC	WEIGHT	COLOR
Fabric or Vinyl	Aluminum: concealed square edge; with 1/8" (3mm) defined joint .	Fabric: Up to 120" x 60" (3050 mm x 1525 mm). Vinyl: Up to 120" x 48" (3050 mm x 1220 mm).	Panel consists of a 6 to 7 pcf (96 to 112 kg/m ³) density core. Fabric corners are fully tailored (no exposed darting). Vinyl corners are heat sealed. A vapor retarder is adhered to panel back.	1" (25 mm)	0.90	0.90 psf (4.40 kg/m ²)	As per finish selected
		Finish width must be sufficient to cover panel, panel thickness, and wrap minimum 1" (25 mm) on back side.		1-1/2" (38 mm)	0.95	1.20 psf (5.90 kg/m ²)	
				2" (50 mm)	1.05	1.52 psf (7.50 kg/m ²)	
Claro or Metallo	Aluminum: Coated with 1/8" (3mm) defined joint.	Recommended Up to 72" x 48" (1830 mm x 1220 mm). Handling larger panels may result in damage to panels. Consult Decoustics for larger panel sizes.	Panel consists of a 6 to 7 pcf (96 to 112 kg/m ³) density acoustically absorptive core, with a special high acoustic performance layer laminated to face (1-1/16" (27 mm) overall thickness) designed to receive a non-bridging acoustically transparent coating. A 1 mil clear vapor retarder is adhered to panel back.	1-1/16" (27 mm)	0.90	1.05 psf (5.15 kg/m ²)	Standard White CSW-100 Light Reflectance 90% Custom Colors to match color chips
Quadrillo	Unfinished square kerf and spline, 3/32" (2.4 mm) edge banding veneer and solid wood face frame. Custom edge profiling on request.	48" x 48" (1220 mm x 1220 mm). Recommended maximum size.	Panel consists of a 6 to 7 pcf (96 to 112 kg/m ³) density mat faced core laminated between a layer of 1/4" (6 mm) thick Quadrillo face and a 1/8" (3 mm) HDF perforated backing board (QPP). Internal fire treated particle board framing as required for edge conditions.	Overall nominal thickness: QPP-19 1-1/8" (28 mm)	0.80	2.80 psf (13.68 kg/m ²)	anigre ash beech cherry mahogany maple oak paint finish pear walnut
				QPP-25 1-3/8" (35 mm)	0.90	3.40 psf (16.61 kg/m ²)	
		For QPP 50 36" x 48" (915 mm x 1220 mm) is the recommended max size due to weight.		QPP-50 2-3/8" (60 mm)	1.00	5.5 psf (26.85 kg/m ²)	

